

TEKTRONIX®

466/464

**STORAGE OSCILLOSCOPE
WITH OPTIONS**

OPERATORS

INSTRUCTION MANUAL

Serial Number _____ First Printing FEB 1974

Tektronix, Inc.
P.O. Box 500
Beaverton, Oregon 97005

070-1652-00

TABLE OF CONTENTS

	Page
BEFORE OPERATING	
Introduction	1
Operating Voltage	1
Safety Information	1
Nominal Line Voltage Range	2
Options	3
CONTROLS, CONNECTORS AND INDICATORS	
Vertical	4
Display and Storage	7
Trigger	8
Horizontal and Power	12
Rear Panel	14
Side Panel	15
P6062A 10X-1X Probe	15
BASIC DISPLAYS	
Normal Sweep Display	16
Magnified Sweep Display	18
Delayed Sweep Display	18
Mixed Sweep Display	19
X-Y Display	19
Single Sweep Display	19

Ⓐ

466/464 Operators

i

	Page
STORAGE DISPLAYS	
Storage	20
Save Storage	22
Save Random Events	22
APPLICATIONS AND MEASUREMENTS	
Preliminary	23
Operator's Adjustments and Checks	24
Peak-to-Peak Voltage Measurements—AC	26
Instantaneous Voltage Measurements—DC	27
Comparison Measurements	28
Time-Duration Measurements	30
Frequency Measurements	30
Risetime Measurements	31
Time-Difference Measurements	32
Multi-Trace Phase Difference Measurements	33
High Resolution Phase Measurements	34
X-Y Phase Measurements	35
Delayed or Mixed Sweep Measurements	36
Pulse Jitter Measurements	38
Algebraic Addition	38
Common-Mode Rejection	40

ii

466/464 Operators

Ⓐ

TABLE OF CONTENTS (cont)

OPERATORS SPECIFICATIONS	Page
Storage	41
Vertical	41
Triggering	42
Horizontal	43
X-Y	43
Calibrator	43
Z Axis Input	44
Outputs	44
AC Power Source	44
Environmental	44
ACCESSORIES	
Standard Accessories Included	45
Optional Accessories	45
OPTIONS	
Option 4	47
Option 7	47
CHANGE INFORMATION	

Ⓐ

466/464 Operators

iii

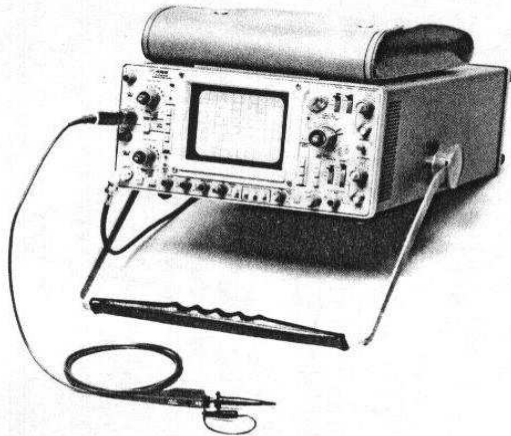

THE ACCESSORY POUCH ILLUSTRATED SHOULD REMAIN ATTACHED TO THE OSCILLOSCOPE. IT IS DESIGNED TO KEEP ACCESSORIES READILY AVAILABLE AND TO AFFORD THE OSCILLOSCOPE SOME PROTECTION IN TRANSIT.

THE ADJUSTABLE CARRYING HANDLE IS DESIGNED TO OFFER CONVENIENT STABLE, OPERATING POSITIONS, SUCH AS THOSE ILLUSTRATED.

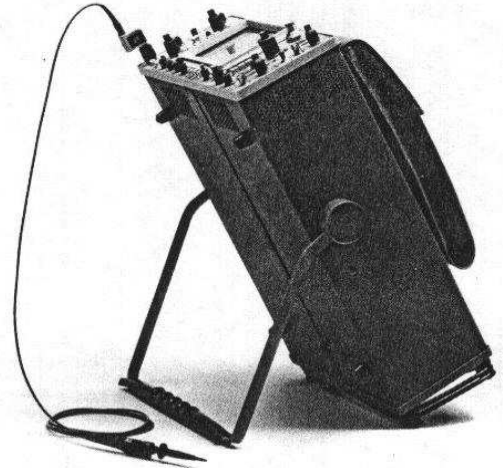

STORAGE OR OPERATION OF THE OSCILLOSCOPE ON ITS FOUR REAR FEET IS NOT DESIRABLE. THE MOST STABLE OPERATING POSITIONS ARE ILLUSTRATED.

466 and 464 Portable Storage Oscilloscopes.

466/464 Operators

BEFORE OPERATING

INTRODUCTION

This Operators Manual provides information necessary to operate the instrument. Included are power requirements; functions of controls, connectors and indicators; and methods for making several different measurements of electrical phenomena. Also included is a procedure for checking basic instrument calibration.

The Tektronix 466 and 464 are dual-channel portable oscilloscopes. The 466 storage system provides storage for displays with a writing speed up to 3000 divisions/microsecond (in the Fast-Reduced Scan mode). The 464 storage system does not have the reduced scan mode and the writing speed is up to 110 divisions/microsecond in the Fast mode. The remaining features are identical. Storage view-time is greater than 15 seconds at full-stored display intensity—extending to more than 6 minutes using reduced intensity in the Save mode.

The dual-channel DC-to-100 MHz vertical system provides calibrated deflection factors from 5 millivolts to 5 volts/division. The sweep trigger circuits are capable of stable triggering over the full bandwidth capabilities of the vertical deflection system. The horizontal deflection system provides calibrated sweep rates from 0.5 seconds to 0.05

Ⓐ

466/464 Operators

1

potential. Operation from power sources where both current-carrying conductors are live with respect to ground (such as phase-to-phase on a three-wire system) is not recommended, since only the Line Conductor has over-current (fuse) protection within the instrument.

The instrument has a three-wire power cord with a three-terminal polarized plug for connection to the power source and safety-earth. The ground (earth) terminal of the plug is directly connected to the instrument frame. For electric-shock protection, insert this plug only in a mating outlet with a safety-earth contact.

NOMINAL LINE VOLTAGE RANGE

CAUTION

This instrument may be damaged if operated with the line voltage selector switch or the regulating range selector set for the wrong applied line voltage.

To convert from one nominal line voltage range to the other, move the Line Voltage Selector switch (located on side panel) to indicate the correct nominal voltage. A

2

microsecond/division along with delayed sweep features for accurate relative-time measurements. A X10 magnifier extends the calibrated sweep rate to 5 nanoseconds/division. The instrument operates over a wide variation of line voltages and frequencies. Maximum power consumption is about 100 watts.

OPERATING VOLTAGE

This instrument operates from either a 115-volt or a 230-volt nominal line voltage source, 48 to 440 hertz.

The line voltage selector switch must indicate the applied line voltage (115 V or 230 V).

The regulating range selector (Item 52, Controls, Connectors and Indicators) must indicate the regulating range for the applied operating line voltage.

SAFETY INFORMATION

The instrument is designed to operate from a single-phase power source with one of the current-carrying conductors (the Neutral Conductor) at ground (earth)

115-to-230 volt adapter may be required for the line-cord plug.

The Regulating Range Selector assembly (located on the rear panel) is set for one of the line voltage ranges shown in Table 1. It also contains the line fuse for overload protection.

TABLE 1

Regulating Ranges

Range Selector Switch Position	Regulating Range	
	115-Volts Nominal	230-Volts Nominal
LO (Switch bar in lower holes)	99 to 121 volts	198 to 242 volts
M (Switch bar in middle holes)	104 to 126 volts	207 to 253 volts
HI (Switch bar in upper holes)	108 to 132 volts	216 to 264 volts
Fuse Size	1.5 A 3AG Fast-blow	0.75 A 3AG Fast blow

466/464 Operators

Ⓐ

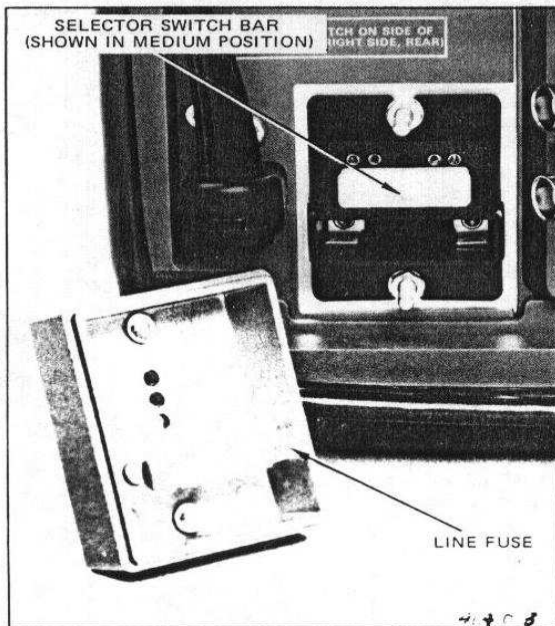

Fig. 1. Regulating range selector and line fuse.

To change the regulating range:

1. Disconnect the instrument from the power source.
2. Loosen the two captive screws that hold the cover on the selector assembly; then pull to remove the cover.
3. Pull out the range selector switch bar (see Fig. 1). Select a range from Table 1 which is centered about the average line voltage. Slide the bar to the desired position and plug it in. Push the cover on and tighten the screws.

OPTIONS

Options are available to alter oscilloscope performance to meet particular applications. A number in either MOD slot (see Item 54, Controls, Connectors and Indicators) indicates a modified oscilloscope.

Refer to the Option section at the rear of this manual to find any change in operating instructions as a result of the option.

(A)

466/464 Operators

3

CONTROLS, CONNECTORS AND INDICATORS

VERTICAL

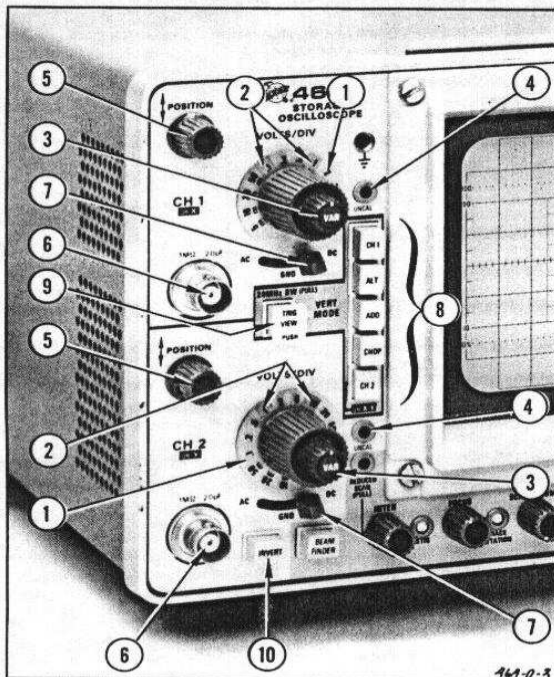

1. **CH 1 and CH 2 VOLTS DIV** – Selects the vertical deflection factor in a 1-2-5 sequence (VARIABLE control must be in the calibrated detent for the indicated deflection factor).

2. **VOLTS/DIV READOUT** – Consists of two small lamps for each channel, located beneath the skirt of each VOLTS/DIV knob. The right lamp will light up to indicate the correct deflection factor when a X10 probe with a scale-switching connector is used. The left lamp lights up when a probe without the scale-switching connection (or no probe) is used.

3. **VAR** – Provides continuously variable uncalibrated deflection factors between the calibrated settings of the VOLTS/DIV switch, and extends the maximum vertical deflection to at least 12.5 volts per division (5 volt position).

4. **UNCAL LAMP** – Indicates when the VARIABLE VOLTS/DIV control is out of the calibrated detent and the vertical deflection factor is uncalibrated.

4

466/464 Operators

REV. B, APR. 1975

5. POSITION — Positions the display vertically. CH 2 POSITION positions the Y-Axis (vertical) display in X-Y Mode.

6. CH 1 OR X and CH 2 OR Y — Input connectors for application of external signals to the inputs of the vertical amplifier. In the X-Y mode of operation, the signal connected to the CH 1 OR X connector provides horizontal deflection and the signal connected to the CH 2 OR Y connector provides the vertical deflection.

7. AC—GND—DC — Selects the method used to couple a signal to the input of the vertical amplifier. In the AC position, signals are capacitively coupled to the vertical amplifier. The dc component of the input signal is blocked. In the GND position, the input of the vertical amplifier is disconnected from the input connector and grounded to allow the input coupling capacitor to precharge. In the DC position, all components of the input signal are passed to the input amplifier.

8. VERT MODE — Selects mode of operation for vertical amplifier system.

CH 1: Channel 1 only is displayed.

ALT: Provides dual-trace display of the signals of both channels. Display is switched between channels at the

end of each sweep. Useful at sweep rates faster than about 50 microseconds/division.

ADD: Signals applied to the CH 1 and CH 2 input connectors are algebraically added, and the algebraic sum is displayed on the crt. The INVERT switch in Channel 2 allows the display to be CH 1 plus CH 2 or CH 1 minus CH 2. Useful for common-mode rejection to remove an undesired signal or for dc offset.

CHOP: Provides dual-trace display of the signals of both channels. Display is switched between channels at a repetition rate of approximately 250 kHz. Useful at sweep rates slower than about 50 microseconds/division, or when a dual-trace, single-sweep display is required.

CH 2: Channel 2 only is displayed. CH 2 must be selected for X-Y operation.

9. 20 MHz BW/TRIG VIEW — Dual-purpose switch that limits the bandwidth of the vertical amplifier system to approximately 20 MHz when pulled, or when pressed, causes the signal applied to A Trigger Generator to be displayed on the crt.

10. INVERT — Channel 2 display is inverted in the INVERT (button in) position.

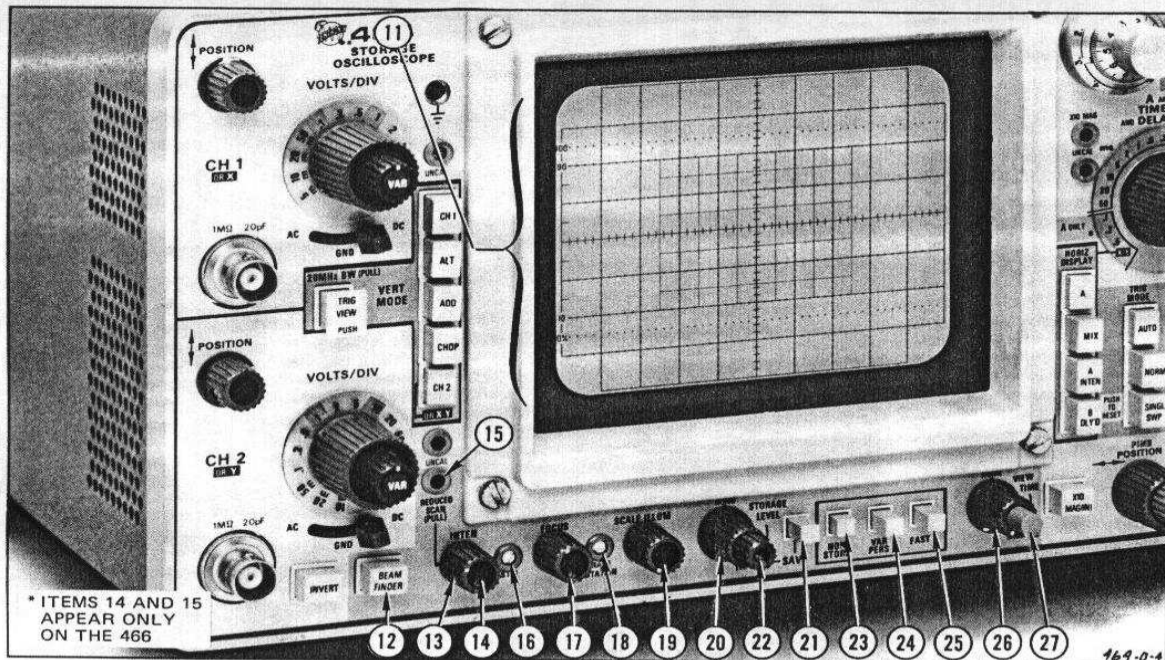

DISPLAY AND STORAGE

11. **INTERNAL GRATICULE** — Eliminates parallax. Risetime amplitude and measurement points are indicated at the left-hand graticule edge.
12. **BEAM FIND** — Compresses the display to within the graticule area independently of display position or applied signals and provides a visible viewing level.
13. **INTEN** — Controls brightness of the crt display.
14. **REDUCED SCAN (PULL — INTEN knob)** — Reduces display to "inner" graticule with an increase in writing rate. 466 only.
15. **REDUCED SCAN LAMP** — Indicates that the REDUCED SCAN mode is in operation. 466 only.
16. **ASTIG** — Used in conjunction with the FOCUS control to obtain a well-defined display. It does not require readjustment in normal use.
17. **FOCUS** — Adjusts for optimum display definition.
18. **TRACE ROTATION** — Adjusts trace to align with the horizontal graticule lines.
19. **SCALE ILLUM** — Controls graticule illumination.

20. **STORAGE LEVEL** — Varies the writing rate of the crt in the FAST and VAR PERS storage modes.
21. **SAVE** — Provides longer viewing time. It prevents accidental erasure of the stored display.
22. **SAVE INTEN** — Varies the intensity of the SAVE mode.
23. **NON STORE** — Allows operation of the instrument as a conventional oscilloscope in the NON STORE mode.
24. **VAR PERS** — Permits variable retention of the stored display.
25. **FAST** — Used for fast-writing displays. FAST mode disables the TRIG MODE switch. It automatically sequences an erase cycle, unless the VIEW TIME control is in the full clockwise detent (manual). It waits a time period determined by the VIEW TIME control, then resets the sweep in a single-sweep mode.
26. **VIEW TIME** — Varies the retention time (persistence) of the stored display in the VAR PERS mode. It varies the time between erase cycles in FAST mode.
27. **ERASE** — Erases the stored display, except in SAVE mode when ERASE is disabled.

Ⓐ

466/464 Operators

7

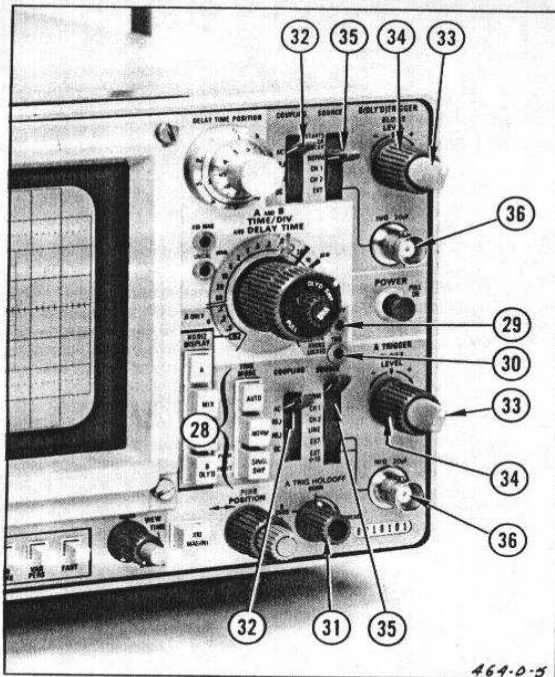

8

466/464 Operators

Ⓐ

TRIGGER

28. **TRIG MODE** — Determines the mode of trigger operation for A Sweep.

AUTO: Sweep is initiated by the applied trigger signal. In the absence of an adequate trigger signal, or if the trigger repetition rate is less than about 20 hertz, the sweep free runs and provides a bright reference trace.

NORM: Sweep is initiated by the applied trigger signal. In the absence of an adequate trigger signal, there is no trace. When the trigger rate is too low for AUTO use NORM.

SINGL SWP: When this pushbutton is pushed, the A Sweep operates in the single sweep mode. After a single sweep is displayed, further sweeps cannot be presented until the SINGL SWP button is pushed. It is useful when the signal to be displayed is not repetitive or varies in amplitude, shape or time, causing an unstable conventional display. It can also be used to photograph or store a non-repetitive signal. In the FAST storage mode, however, the single-sweep rate (and erase cycle) is determined by the VIEW TIME control.

29. READY LAMP — Indicates A Sweep is “armed” and, upon receipt of an adequate trigger signal, will present a single-sweep display.

30. TRIG LAMP — Indicates that A Sweep is triggered and will produce a stable display. It is useful for setting up the trigger circuits when a trigger signal is available without a display on the crt (for example, when using external triggers).

31. A TRIG HOLDOFF — Provides continuous control of time between sweeps. Allows triggering on aperiodic signals (such as, complex digital words). In the fully clockwise position (B ENDS A), A sweep is reset at the end of B sweep to provide the fastest possible sweep repetition rate for delayed-sweep presentations and low-repetition rate signals. Use the A trigger controls for the best possible display before using the A TRIG HOLDOFF control.

32. COUPLING — Determines method used to couple signals to trigger generator circuit.

AC: Signals are capacitively coupled to the input of the trigger generator. Dc is rejected and signals below about 30 Hz are attenuated.

LF REJ: Signals are capacitively coupled to the input of the trigger circuit. Dc is rejected and signals below about 50 kHz are attenuated. It is useful for providing a stable display of the high-frequency components of a complex waveform.

HF REJ: Signals are capacitively coupled to the input of trigger circuit. Dc is rejected and signals below about 30 Hz and above about 50 kHz are attenuated. It is useful for providing a stable display of the low-frequency components of a complex waveform.

DC: All components of a trigger signal are coupled to the input of the trigger circuit. It is useful for providing a stable display of low-frequency or low-repetition rate signals, except the combination of ALT (dual trace) mode with the trigger SOURCE switch in NORM.

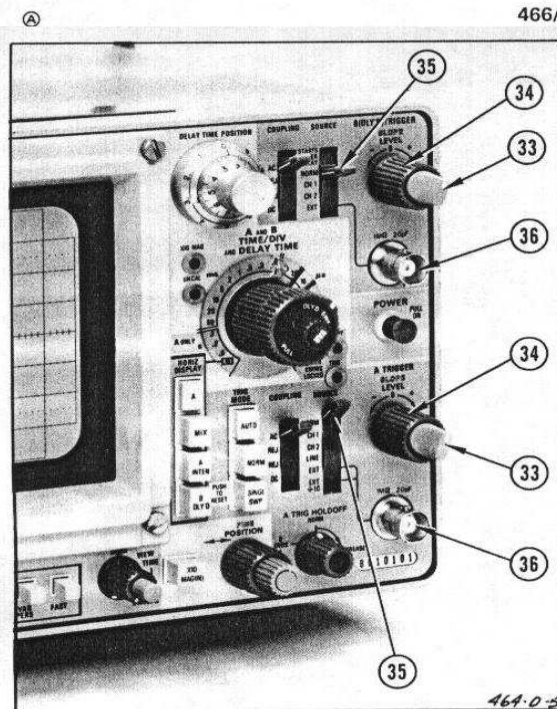

466/464 Operators

TRIGGER (cont)

33. SLOPE — Selects the slope of the trigger signal that starts the sweep.

+: Sweep can be triggered from the positive-going portion of a trigger signal.

-: Sweep can be triggered from the negative-going portion of a trigger signal.

Correct SLOPE setting is important in obtaining a display when only a portion of a cycle is being displayed.

34. LEVEL — Selects the amplitude point on the trigger signal at which the sweep is triggered. It is usually adjusted for the desired display after trigger SOURCE, COUPLING and SLOPE have been selected.

35. SOURCE — Determines the source of the trigger signal coupled to the input of the trigger circuit.

NORM: Trigger source is displayed signal(s). It does not indicate time relationship between CH 1 and CH 2 signals. However, stable triggering of non-time related signals usually can be obtained by setting VERT MODE to ALT, SOURCE to NORM and COUPLING to LF REJ. Carefully adjust LEVEL for a stable display.

CH 1: A sample of the signal available in Channel 1 is used as a trigger signal. CH 2 signal is unstable if it is not time-related.

CH 2: A sample of the signal available in Channel 2 is used as a trigger signal. CH 1 signal is unstable if it is not time related.

LINE (A Trigger circuit only): A sample of the power-line frequency is used as a trigger signal. It is useful when input signal is time-related (multiple or sub-multiple) to the line frequency or when it is desirable to provide a stable display of a line-frequency component in a complex waveform.

EXT: Signals connected to the External Trigger Input connectors are used for triggering. External signals must be time-related to the displayed signal for a stable display. It is useful when the internal signal is too small or contains undesired signals that could cause unstable triggering. It is useful when operating in CHOP Mode.

EXT \div 10 (A Trigger circuit only): External trigger signal attenuated by a factor of 10.

STARTS AFTER DELAY (B Trigger circuit only): B Sweep runs immediately after the delay time selected by the DELAY-TIME POSITION dial.

36. EXTERNAL TRIGGER INPUT — Input connector for external trigger signals.

Ⓐ

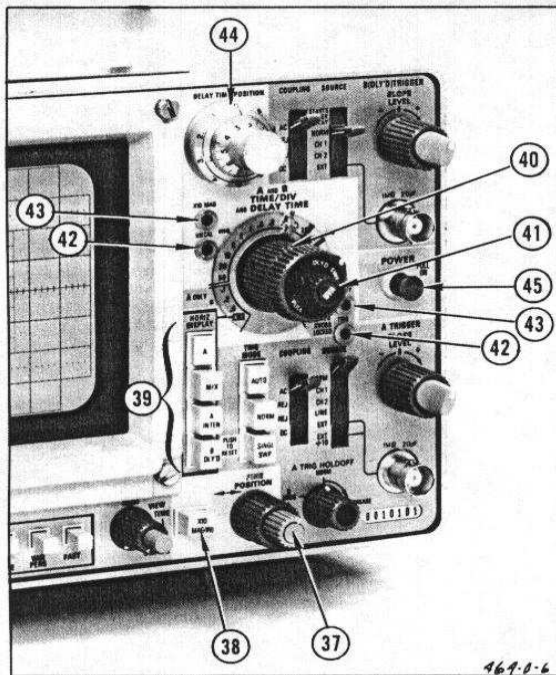

HORIZONTAL AND POWER

37. FINE/POSITION — Positions the display horizontally for A Sweep, B Sweep or the X-axis in X-Y Mode.

38. X10 MAG — Increases displayed sweep rate by a factor of 10. It extends fastest sweep rate to 5 nano-seconds/division. The magnified sweep is the center division of the unmagnified display (0.5 division either side of the center graticule line).

39. HORIZ DISPLAY — Determines mode of operation for horizontal deflection system.

A: Horizontal deflection provided by A Sweep at a sweep rate determined by the setting of the A TIME/DIV switch. B Sweep is inoperative.

MIX: First part of the horizontal sweep displayed at a rate set by the A TIME/DIV switch and the latter part of the sweep at a rate set by the B TIME/DIV switch. Relative amounts of the display allocated to each of the two sweep rates are determined by the setting of the DELAY-TIME POSITION dial.

A INTEN: Sweep rate determined by the A TIME/DIV switch. An intensified portion appears on the display during the B Sweep time, which is about 10 times the B TIME/DIV switch setting. This switch position provides

a check of the duration and position of the B Sweep (delayed sweep) with respect to the delaying sweep (A).

B DLYD: Sweep rate determined by the B TIME/DIV switch with the delay time determined by the setting of the DELAY TIME (A TIME/DIV) switch and the DELAY-TIME POSITION dial.

40. A AND B TIME/DIV AND DELAY TIME — A TIME/DIV switch (clear plastic skirt) selects the sweep rate of the A Sweep circuit for A Sweep only operation and selects the basic delay time (to be multiplied by DELAY TIME POSITION dial setting) for delayed sweep operation. B TIME/DIV switch (pull out and rotate to unlock) selects sweep rate for the B Sweep circuit for delayed sweep operation only. A VAR control must be in the calibrated detent for calibrated sweep rates. When both TIME/DIV switches are fully counterclockwise to the X-Y position, the horizontal (X-axis) display is the CH 1 input.

41. VAR — Provides continuously variable sweep rates between the calibrated settings of the A TIME/DIV switch. It extends the slowest A Sweep rate to at least 1.25 seconds/division. The A Sweep rate is calibrated when the control is set fully clockwise to the calibrated detent.

42. UNCAL LAMP — Indicates the A Sweep rate is uncalibrated (VAR control out of the calibrated detent).

43. X10 MAGnifier LAMP — Indicates that the X10 magnifier is on.

44. DELAY-TIME POSITION — Provides variable sweep delay from 0.20 to 10.20 times the delay time indicated by the A TIME/DIV switch.

45. POWER — Turns instrument power on and off.

(A)

466/464 Operators

13

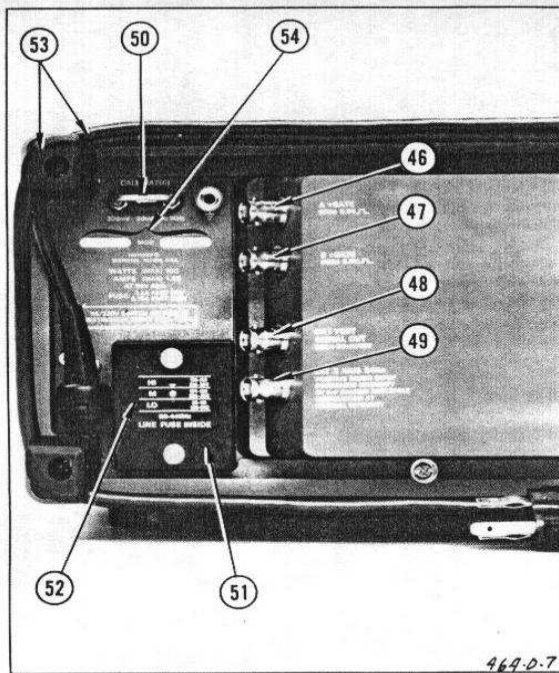

REAR PANEL

46. A +GATE — Provides a positive-going rectangular pulse coincident with the A Sweep time, which can be used to trigger the signal source.

47. B +GATE — Provides a positive-going rectangular pulse coincident with the B Sweep time, which can be used to trigger the signal source after a selected delay time, providing that A Sweep is triggered internally.

48. CH 1 VERT SIGNAL OUT — Provides a sample of the signal applied to the CH 1 input connector.

49. EXT Z-AXIS — Permits intensity modulation of the crt display. Does not affect display waveshape. Signals with fast rise and fall provide the most abrupt intensity change. Signal must be time-related to the display for a stable display. Useful for uncalibrated modes of operation and adding time markers.

50. CALIBRATOR — A combination current loop/square-wave voltage output that permits the operator to compensate voltage probes and check vertical gain, current probes and oscilloscope operation. It is not intended to verify time-base calibration.

51. LINE FUSE HOLDER — Contains the line fuse and the regulating range selector. See Fig. 1 for change information.

14

466/464 Operators

(A)

52. **REGULATING RANGE SELECTOR** — Shown in Medium regulating range. See Fig. 1 for change information.

53. **LINE CORD** — May be conveniently stored by wrapping it around the feet on the rear panel or the accessory pouch.

54. **MOD Slots** — A number in either slot indicates the instrument contains an option.

SIDE PANEL

55. **LINE VOLTAGE SELECTOR SWITCH** (located on the right-hand side) — Selects either 115 V or 230 V nominal line voltage.

P6062A 10X — 1X PROBE

1. **10X — 1X SLIDE SWITCH** — Selects either 10X or 1X attenuation factor. The oscilloscope VOLTS/DIV readout reflects the change in attenuation.

2. **GND REFERENCE PUSHBUTTON** — Grounds the input of the vertical amplifier. The input signal is isolated from ground by about 9 M Ω and 11 pF, in either 1X or 10X operation. Pushbutton must be completely depressed to obtain the ground reference.

3. **PROBE COMPENSATION ADJUSTMENT** — Permits adjusting an individual probe to the input variations between different oscilloscopes.

4. **READOUT CONNECTOR** — Permits scale switching of the VOLTS/DIV switch when the position of 10X — 1X slide switch is changed.

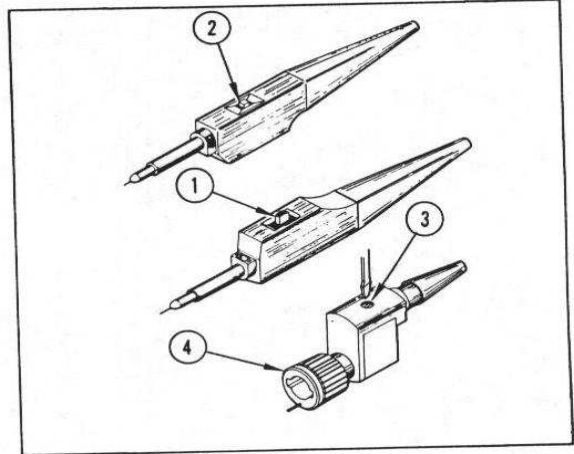

Fig. 2. P6062A probe.

BASIC DISPLAYS

15

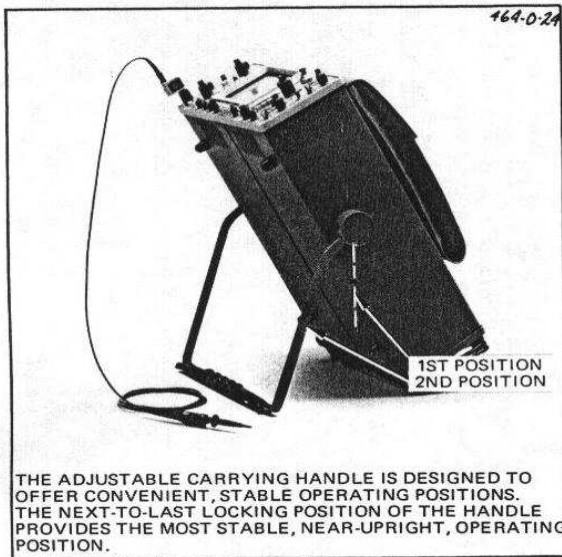

Fig. 3. Tilted operation.

These instructions permit the operator to obtain the commonly used basic displays.

NORMAL SWEEP DISPLAY

1. Set the controls as follows:

VERTICAL

VERT MODE	CH 1.
VOLTS/DIV	Position determined by amplitude of signal to be applied.
VOLTS/DIV VAR	Calibrated detent.
Input Coupling	AC.
Vertical POSITION	Midrange.
20 MHz BW	Not limited (yellow band not visible).
INVERT	Button out.

16

466/464 Operators

Ⓐ

DISPLAY	
INTENSITY	Fully counterclockwise.
REDUCED SCAN (PULL)	Pushed in.
FOCUS	Midrange.
SCALE ILLUM	Midrange.
STORAGE LEVEL	NORM.
SAVE INTEN	Fully counterclockwise.
SAVE	Button out.
NON STORE	Button in.
VIEW TIME	NORM.

TRIGGER	
Trigger	(Both A and B if applicable).
SLOPE	+
LEVEL	0.
SOURCE	NORM.
COUPLING	AC.

TRIG MODE (A only)	
	AUTO.
A TRIG HOLDOFF	NORM.

HORIZONTAL	
TIME/DIV Switches	Locked together at 1 ms.
A TIME/DIV VAR	Calibrated detent.
HORIZ DISPLAY	A
X10 MAG	Off (button out)
POSITION	Midrange

2. Pull the POWER switch (on) and allow several minutes for warmup. Connect the external signal to the CH 1 input connector.

3. Adjust the INTENSITY control for the desired display brightness. If the display is not visible with the INTENSITY control at midrange, press the BEAM FIND pushbutton and adjust the CH 1 VOLTS/DIV switch to reduce the vertical display size. Center the compressed display with the vertical and horizontal POSITION controls; release the BEAM FIND pushbutton. Adjust the FOCUS control for a well-defined display.

Ⓐ

466/464 Operators

17

4. Set the CH 1 VOLTS/DIV switch and vertical POSITION control to locate the display within the display area.

5. Adjust the A Trigger LEVEL control for a stable display.

6. Set the A TIME/DIV switch and the horizontal POSITION control to locate the display within the display area.

MAGNIFIED SWEEP DISPLAY

1. Obtain a Normal Sweep Display.

2. Adjust the horizontal POSITION control to move the area to be magnified to within the center graticule division. (It may be necessary to change the TIME/DIV switch setting.)

3. Push the X10 MAG switch (on) and adjust the horizontal POSITION control for precise positioning of the magnified display. Divide the TIME/DIV setting by 10 to determine the magnified sweep rate.

DELAYED SWEEP DISPLAY

1. Obtain a Normal Sweep Display.

2. Set the HORIZ DISPLAY switch to A INT and the B Trigger SOURCE switch to STARTS AFTER DELAY.

3. Pull out the B TIME/DIV switch knob and turn clockwise so the intensified zone on the display is the desired length. Adjust the INTENSITY control for the desired display brightness.

4. Adjust the DELAY-TIME POSITION dial to move the intensified zone to the portion of the display to be delayed.

5. Set the HORIZ DISPLAY switch to B DLY'D. The intensified zone on the display noted in steps 3 and 4 is now displayed in delayed form. The delayed sweep rate is indicated by the dot on the B TIME/DIV switch knob.

6. For a delayed sweep display with less jitter, set the B Trigger SOURCE switch to the same position as the A Trigger SOURCE switch and adjust the B Trigger LEVEL control for a stable display. If the A Trigger SOURCE switch is in the LINE position, a sample of the line voltage will have to be supplied to the B Trigger circuit externally via the B Trigger external trigger connector.

18

466/464 Operators

Ⓐ

MIXED SWEEP DISPLAY

1. Obtain a Normal Sweep Display.
2. Pull out the B TIME/DIV switch knob and turn clockwise to the desired sweep rate. Adjust the INTENSITY control for the desired display brightness.
3. Set the HORIZ DISPLAY switch to MIX. The display now contains more than one time factor on the horizontal axis. The first portion of the display is at the A Time Base sweep rate and the latter part is at the B Time Base sweep rate. The start of the B Time Base portion of the display can be changed by adjusting the DELAY-TIME POSITION control.

X-Y DISPLAY

1. Preset the instrument controls as given in step 1 of Normal Sweep Display, then turn the instrument power on. Allow several minutes for instrument warm-up.
2. Set the TIME/DIV switches to X-Y and the VERT MODE to CH 2. Apply the vertical signal to the CH 2 OR Y input connector and the horizontal signal to the CH 1 OR X input connector.
3. Advance the INTENSITY control until the display is visible. If the display is not visible with the INTENSITY

control at midrange, press the BEAM FIND pushbutton and adjust the CH 1 and CH 2 VOLTS/DIV switches until the display is reduced in size, both vertically and horizontally. Center the compressed display with the POSITION controls (CH 2 POSITION vertically, POSITION/FINE horizontally); release the BEAM FIND pushbutton. Adjust the FOCUS control for a well-defined display.

SINGLE SWEEP DISPLAY

1. Obtain a Normal Sweep Display. (For random signals, set the trigger circuit to trigger on a signal that is approximately the same amplitude and frequency as the random signal.)
2. Set the A TRIG MODE switch to SINGL SWP and press the PUSH TO RESET button. The next trigger pulse starts the sweep and displays a single trace. If no triggers are present, the READY lamp lights, indicating the A Sweep Generator circuit is set and waiting to be triggered.
3. After the sweep is complete, the circuit is "locked out" and the READY lamp is out. Press the PUSH TO RESET button to prepare the circuit for another single-sweep display.

Ⓐ

466/464 Operators

19

STORAGE DISPLAYS

STORAGE

1. Obtain a Normal Sweep Display as follows:
2. Set the following controls:

VERTICAL	
VERT MODE Switch	CH 1.
VOLTS/DIV Switches	Determined by amplitude of applied signal.
VOLTS/DIV VAR Controls	Calibrated detent.
Input Coupling Switches	AC
Vertical POSITION Controls	Midrange
20 MHz BW Switch	Not limited (yellow band not visible)
INVERT Switch	Button out

DISPLAY	
INTENSITY Control	Fully counterclockwise
REDUCED SCAN (PULL) Switch	Push (466 only)
FOCUS Control	Midrange
SCALE ILLUM Control	Midrange
STORAGE LEVEL Control	NORM
SAVE INTEN Control	Fully counterclockwise
SAVE Switch	Button out
NON STORE Switch	Button in
VIEW TIME Control	NORM

20

466/464 Operators

Ⓐ

TRIGGER (Both A and B if applicable)	
SLOPE Switch	+
LEVEL Control	0
SOURCE Switch	NORM
COUPLING Switch	AC
TRIG MODE Switch (A only)	AUTO
A TRIG HOLDOFF Control	NORM

HORIZONTAL	
TIME/DIV Switches	Locked together at 1ms
A TIME/DIV VAR	Calibrated detent
HORIZ DISPLAY Switch	A
X 10 MAG Switch	Off (button out)
POSITION Control	Midrange

Ⓐ

466/464 Operators

21

NOTE

a. In general, better results are obtained using the VAR PERS mode for sweep speeds slower than 100 μ s/division.

b. When using the combination of FAST storage and B DLY'D horizontal display, set A TRIG HOLDOFF control to B ENDS A for maximum display repetition rate.

9. Push the ERASE button. Allow a few seconds for the storage and trigger circuits to automatically provide a display.

10. Set the INTENSITY control for adequate display brightness. Set the STORAGE LEVEL control for optimum display (depends on the amplitude and speed of the signal to be viewed). Set the VIEW TIME control for the desired display retention (persistence) in the VAR PERS mode or for the time between erase cycles in the FAST mode.

11. Push the ERASE button. The display is erased, except in the SAVE mode, and the storage and trigger circuits are reset.

22

466/464 Operators

Ⓐ

3. Pull the POWER switch (on) and allow several minutes for instrument warmup. Connect the external signal to the CH 1 input connector.

4. Adjust the INTENSITY control for the desired display brightness. If the display is not visible with the INTENSITY control at midrange, press the BEAM FIND pushbutton and adjust the CH 1 VOLTS/DIV switch to reduce the vertical display size. Center the compressed display with the vertical and horizontal POSITION controls; release the BEAM FIND pushbutton. Adjust the FOCUS control for a well-defined display.

5. Set the CH 1 VOLTS/DIV switch and CH 1 POSITION CONTROL for a display that remains in the display area vertically.

6. Adjust the A Trigger LEVEL control for a stable display.

7. Set the A TIME/DIV switch and the horizontal POSITION control for a display that remains in the display area horizontally.

8. Set the STORAGE LEVEL and VIEW TIME controls to NORM. Set the SAVE switch button out. Select either VAR PERS or FAST mode.

SAVE STORAGE

1. Obtain a Storage Display using steps 1 through 10.

2. Immediately after the event is stored, push in the SAVE button, providing a longer viewing time. The SAVE INTENS control adjusts the display brightness. Increasing the display brightness decreases the viewing time.

Pushing the SAVE button, after the event is stored, can be delayed up to several seconds (depending on the VIEW TIME setting), this reduces maximum viewing time.

Maximum viewing time occurs when the SAVE INTENS control is set fully counterclockwise, advancing the control only long enough to view the display.

3. Erase is disabled in the SAVE mode.

SAVE RANDOM EVENTS

1. Obtain a Storage Display using steps 1 through 10, with a test signal similar to a random event. Use the FAST mode, not VAR PERS.

2. Set the SAVE INTEN control to maximum counterclockwise. Replace the test signal with the random event source. Push the ERASE button (or wait for the erase cycle to occur). Note that the READY lamp is on. Push in the SAVE button before the event occurs.

3. After the event is captured, the oscilloscope will automatically drop into the SAVE mode.

APPLICATIONS AND MEASUREMENTS

Once the new user has familiarized himself with obtaining basic displays including the Operator's adjustments and checks, the following applications will aid him in taking measurements.

Refer to Basic Displays as needed to obtain correct displays.

PRELIMINARY

SIGNAL GROUND. The most reliable signal measurements are made when the oscilloscope and the unit under test are connected together by a common reference (ground) lead in addition to the signal lead or probe. The ground strap on the signal probe provides the best ground. Also, a ground lead can be connected to the ground banana jack on the oscilloscope chassis to establish a common ground with the signal source.

INPUT COUPLING CAPACITOR PRECHARGING. In the GND position, the input signal is connected to ground through a one-megohm resistor to form a pre-charging network. This network allows the Input Coupling capacitor to charge to the average dc voltage level of the signal applied to the probe. Thus, any large voltage transients

accidentally generated will not be applied to the amplifier input. The pre-charge network also provides a measure of protection to the external circuitry to reducing the current levels that can be drawn from the external circuitry during capacitor charging.

The following procedure should be used whenever the probe tip is connected to a signal source having a different dc level than that previously applied.

1. Before connecting the probe tip to a signal source, set the Input Coupling switch to GND.
2. Touch the probe tip to oscilloscope chassis ground. Wait several seconds for the Input Coupling capacitor to discharge.
3. Connect the probe tip to the signal source.
4. Wait several seconds for the Input Coupling capacitor to charge.
5. Set the Input Coupling Switch to AC. The display will remain on screen so the ac component of the signal can be measured in the normal manner.

Ⓐ

466/464 Operators

23

OPERATOR'S ADJUSTMENTS AND CHECKS

To verify measurement accuracy, perform the following checks and adjustments before making a measurement. See the Calibration section of the Service Manual for calibration information.

TRACE ROTATION ADJUSTMENT. (Typically not required.) Obtain a Normal Sweep Display using only steps 1 through 3. Set the CH 1 Input Coupling switch to GND to display a free-running trace with no vertical deflection. Adjust the TRACE ROTATION (located below the crt graticule) to align the trace with the center horizontal graticule line.

PROBE COMPENSATION. (One of the greatest sources of operator error.) Most attenuator probes are equipped with adjustments to ensure optimum measurement accuracy. Probe compensation is accomplished as follows:

Obtain a Normal Sweep Display presentation of the calibrator square-wave voltage. Set the appropriate VOLTS/DIV switch to the .1 V position and the Input Coupling to DC. Check the waveform presentation for overshoot or rolloff, and, if necessary, readjust compensation for flat tops on the waveforms. See Fig. 4.

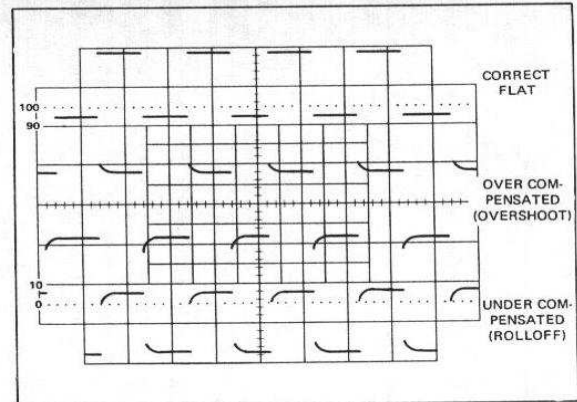

Fig. 4. Probe compensation.

VERTICAL GAIN CHECK. Obtain a Normal Sweep Display presentation of the calibrator square-wave voltage. Set the appropriate VOLTS/DIV switch to the 50 mV position and the Input Coupling switch to DC. Make sure

24

466/464 Operators

Ⓐ

the VAR VOLTS/DIV control is in the calibrated detent. Check that the vertical deflection is 5.8 to 6.2 divisions.

BASIC TIMING CHECK (60 HERTZ ONLY). Obtain a Normal Sweep Display of the ac power line. Set the A TIME/DIV switch to the 2 ms position. Make sure the VAR TIME/DIV control is in the calibrated detent. Use the POSITION and A TRIGGER LEVEL controls to position the display so the positive-going portion of the signal crosses the center horizontal graticule one division from the left-hand graticule edge (see Fig. 7). The distance between

this point and the point where the positive-going portion again crosses the center graticule line is 8.1 to 8.6 divisions.

EXTERNAL HORIZONTAL GAIN CHECK. (If X-Y operation is to be used) Use steps 1 through 3 of the procedure for obtaining a Normal Sweep Display of the calibrator square-wave voltage waveform; then, set the TIME/DIV switch to X-Y. With the calibrator signal connected to the CH 1 OR X input connector and the CH 1 VOLTS/DIV switch set to 50 mV, the crt display should be two dots separated horizontally by 5.75 to 6.25 divisions.

Ⓐ

PEAK-TO-PEAK VOLTAGE MEASUREMENTS—AC

Oscilloscopes measure peak-to-peak voltage, not rms.

This method may be used to make measurements between two points on the waveform, rather than peak-to-peak.

If the amplitude measurement is critical or the trace is thick as a result of noise, hum, etc. on the signal, a more accurate measurement is to measure from the peak of the signal to the valley. This method subtracts the trace thickness from the measurement.

Make sure the VAR VOLTS/DIV control is in the calibrated detent. Vertically position the display so the lower portion coincides with a graticule line and the upper portion is in the viewing area. Horizontally position the display so one of the upper peaks lies near the center vertical line (see Fig. 5).

Measure the divisions of vertical deflection from peak to peak. Make sure the VAR VOLTS/DIV control is in the calibrated detent.

Multiply the vertical deflection by the VOLTS/DIV switch setting. Also include the attenuation factor of the probe, if the probe does not have a scale-factor switching connector.

EXAMPLE: The peak-to-peak vertical deflection measured is 4.6 divisions (see Fig. 5) with a VOLTS/DIV switch setting of .5.

Using the formula:

$$\text{Volts Peak-to-Peak} = \text{vertical deflection (divisions)} \times \text{VOLTS/DIV setting}$$

Substituting the given values:

$$\text{Volts Peak-to-Peak} = 4.6 \times 0.5 \text{ V} = 2.3 \text{ volts.}$$

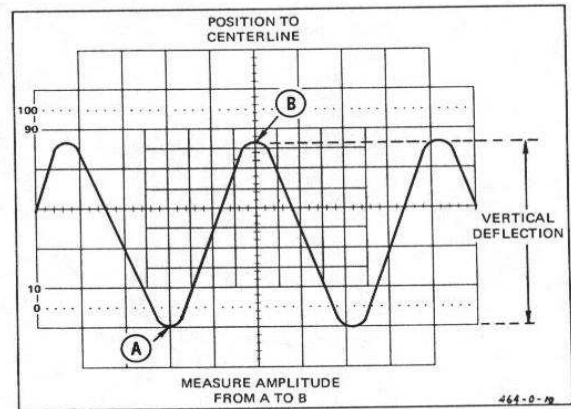

Fig. 5. Peak-to-peak voltage of a waveform.

INSTANTANEOUS VOLTAGE MEASUREMENTS – DC

Make sure the VAR VOLTS/DIV control is in the calibrated detent. Set the Input Coupling Switch to GND. Establish the polarity of the signal. If the waveform is above the reference line, the voltage is positive; below the line, negative. Position the trace to the bottom graticule line or other reference line, if a positive voltage is to be measured. Do not move the vertical POSITION control after this reference line is established.

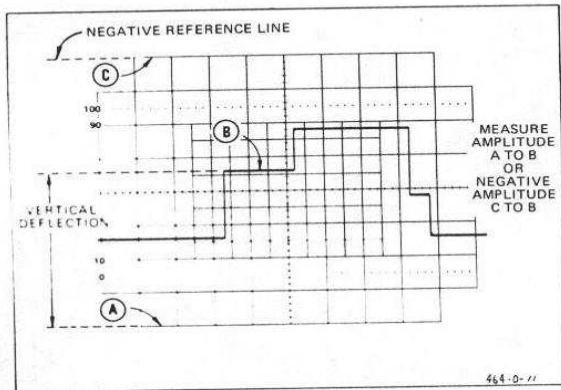

Fig. 6. DC voltage with respect to a reference line.

Switch the Input Coupling Switch to DC. Measure the divisions of vertical deflection between the reference line and the desired point on the waveform (see Fig. 6). Multiply the vertical deflection by the VOLTS/DIV switch setting. Include the attenuation factor of the probe if the probe does not have a scale-factor switching connector.

EXAMPLE: The vertical distance measured is 4.6 divisions (see Fig. 6), the waveform is above the reference line, and the VOLTS/DIV switch is set to 2.

Using the formula:

$$\text{Instantaneous Voltage} = \text{vertical distance (divisions)} \times \text{polarity} \times \text{VOLTS/DIV setting}$$

Substituting: = 4.6 X +1 X 2V = 9.2 volts.

If a negative voltage is to be measured, position the trace to the top graticule line and measure from C to B (see Fig. 6).

The ground reference line can be checked at any time by switching to the GND position.

To measure a voltage level with respect to another voltage level, position the reference voltage to the reference line and make the measurement.

Ⓐ

466/464 Operators

27

COMPARISON MEASUREMENTS

ARBITRARY VERTICAL DEFLECTION FACTOR.

The desired signal amplitude to be measured may not be an exact number of divisions of deflection. If the measurement is repetitious (e.g., on an assembly-line test), it is possible to obtain more accurate, easily-read measurements if the VOLTS/DIV switch and the VAR VOLTS/DIV control are adjusted to set the desired signal amplitude to an exact number of divisions. Be careful not to move the VAR VOLTS/DIV control after obtaining the desired deflection.

The signal amplitude just established may be used as a reference for amplitude comparison measurements.

The amplitude of the reference signal must be known to establish an arbitrary deflection factor to measure the amplitude of an unknown signal. If the reference signal amplitude is unknown, measure it before moving the VAR VOLTS/DIV control from the calibrated position.

Determine the vertical conversion factor using this formula:

$$\text{Vertical Conversion Factor} = \frac{\text{reference signal amplitude (volts)}}{\text{vertical deflection (divisions)} \times \text{VOLTS/DIV switch setting}}$$

Connect the unknown signal to the input connector. Set the VOLTS/DIV switch to a setting that provides sufficient

vertical deflection to make an accurate measurement. Do not readjust the VAR VOLTS/DIV control.

Measure the vertical deflection in divisions and calculate the amplitude of the unknown signal using the following formula:

$$\text{Signal Amplitude} = \text{VOLTS/DIV switch setting} \times \text{vertical conversion factor} \times \text{vertical deflection (divisions)}$$

EXAMPLE: The reference signal amplitude measured is 30 volts with a VOLTS/DIV switch setting of 5 and the VAR VOLTS/DIV control adjusted to provide a vertical deflection of 4 divisions.

Substituting these values in the vertical conversion factor formula:

$$\text{Vertical Conversion} = \frac{30 \text{ V}}{4 \times 5 \text{ V}} = 1.5$$

Then with a VOLTS/DIV switch setting of 1, the peak-to-peak amplitude of an unknown signal, 5 divisions high can be determined by using the signal amplitude formula:

$$\text{Signal Amplitude} = 1 \text{ V} \times 1.5 \times 5 = 7.5 \text{ volts.}$$

Arbitrary Sweep Rates. The desired signal time to be measured may not be an exact number of divisions of deflection. If the measurement is repetitious (e.g. on an assembly-line test), it is possible to obtain more accurate,

28

466/464 Operators

Ⓐ

easily-read measurements if the TIME/DIV switch and the VAR TIME/DIV control are adjusted to set the desired signal timing to an exact number of divisions. Be careful not to move the VAR TIME/DIV control after obtaining the desired deflection.

The signal timing just established may be used as a reference for time comparison measurements.

The repetition rate of the reference signal must be known to establish an arbitrary sweep rate to measure the repetition rate of the unknown signal. If the reference signal repetition rate is unknown, measure it before moving the VAR TIME/DIV control from the calibrated position.

Determine the horizontal conversion factor using the formula:

$$\text{Horizontal Conversion Factor} = \frac{\text{reference signal repetition rates (seconds)}}{\text{horizontal deflection (divisions)} \times \text{TIME/DIV switch setting}}$$

Connect the unknown signal to the input connector. Set the TIME/DIV switch to a setting that provides sufficient horizontal deflection to make an accurate measurement. Do not readjust the VAR TIME/DIV control.

Measure the horizontal deflection in divisions and calculate the repetition rate of the unknown signal using the following formula:

$$\text{Repetition Rate} = \frac{\text{TIME/DIV switch setting}}{\text{horizontal conversion factor} \times \text{horizontal deflection (divisions)}}$$

If the horizontal magnifier is used, be sure to use the magnified sweep rate in place of the TIME/DIV switch setting.

EXAMPLE: The reference signal frequency measured is 455 hertz (repetition rate, 2.19 milliseconds) with a TIME/DIV switch setting of .2 ms, and the VAR TIME/DIV control adjusted to provide a horizontal deflection of eight divisions. Substituting these values in the horizontal conversion factor formula:

$$\text{Horizontal Conversion Factor} = \frac{2.19 \text{ milliseconds}}{0.2 \times 8} = 1.37$$

Then, with a TIME/DIV switch setting of 50 μ s, the repetition rate of an unknown signal that completes one cycle in seven horizontal divisions can be determined by using the repetition rate formula:

$$\text{Repetition Rate} = 50 \mu\text{s} \times 1.37 \times 7 = 480 \mu\text{s}$$

This answer can be converted to frequency by taking the reciprocal of the repetition rate (see applications on Determining Frequency).

Ⓐ **TIME-DURATION MEASUREMENTS**

Be sure the VAR TIME/DIV control is set to the calibrated detent. Set the TIME/DIV switch for a single event and position the display to place the time measurement points to the center horizontal line (see Fig. 7).

Measure the horizontal distance between the time measurement points. Multiply the distance measured by the setting of the TIME/DIV switch. If sweep magnification is used, divide this answer by 10.

EXAMPLE: The distance between the time measurement point is 8.3 divisions (see Fig. 7) and the TIME/DIV switch is set to 2 ms with the magnifier off.

Using the formula:

$$\text{Time Duration} = \frac{\text{horizontal distance (divisions)} \times \text{TIME/DIV setting}}{\text{magnification}}$$

Substitute the given values:

$$\text{Time Duration} = \frac{8.3 \times 2 \text{ ms}}{1} = 16.6 \text{ milliseconds}$$

FREQUENCY MEASUREMENTS

Time measurements can be used to determine the frequency of a periodically recurrent signal as follows:

1. Measure one cycle of the waveform as described in Time-Duration Measurements.
2. Take the reciprocal of the time duration to determine the frequency.

EXAMPLE: The frequency of the signal shown in Fig. 7, which has a time duration of 16.6 milliseconds is:

$$\text{Frequency} = \frac{1}{\text{time duration}} = \frac{1}{16.6 \text{ ms}} = 60 \text{ hertz}$$

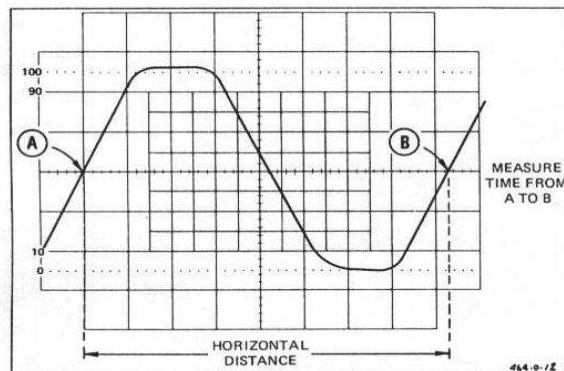

Fig. 7. Time duration between points on a waveform.

RISETIME MEASUREMENTS

Risetime measurements use the same methods as time-duration measurements, except the measurements are made between the 10% and 90% points of the waveform. Falltime is measured between the 90% and 10% points on the trailing edge of the waveform.

Use a sweep speed setting that displays several cycles or events (if possible) and be sure the VAR TIME/DIV control is in the calibrated detent. Set the VOLTS/DIV switch and VAR control (or signal amplitude) for exactly a five-division display. Set vertical positioning so the display bottom touches the 0% graticule line and the display top touches the 100% graticule line.

Set the TIME/DIV switch for a single-event display and horizontally position the display so the 10% point of the waveform intersects the second vertical graticule line (see Fig. 8).

Measure the horizontal distance between the 10% and 90% points and multiply the distance measured by the setting of the TIME/DIV switch.

EXAMPLE: The horizontal distance between the 10% and 90% points is 5 divisions (see Fig. 8) and the TIME/DIV switch is set to 1 μ s.

Using the time duration formula to find risetime:

$$\text{Time Duration (risetime)} = \frac{\text{horizontal distance (divisions)}}{\text{setting}} = \text{TIME/DIV setting}$$

Substituting the given values:

$$\text{Risetime} = 5 \times 1 \mu\text{s} = 5 \text{ microseconds}$$

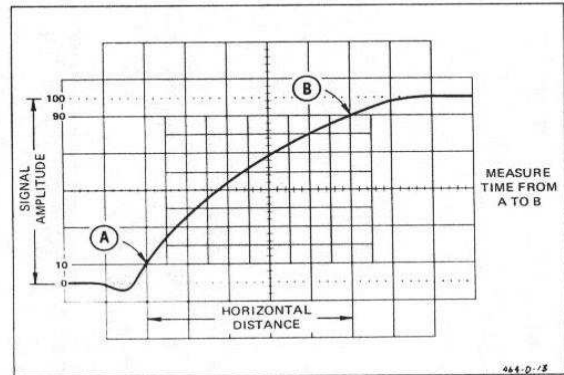

Fig. 8. Risetime.

Ⓐ

466/464 Operators

31

TIME-DIFFERENCE MEASUREMENTS

Make sure the VAR TIME/DIV control is in the calibrated detent. Set the A Trigger SOURCE switch to CH 1. Connect the reference signal to CH 1 and the comparison signal to CH 2. Connect the signals to the input connectors using probes or cables with equal time delay.

Set the VERT MODE switch to either CHOP or ALT. In general, CHOP is more suitable for low-frequency signals

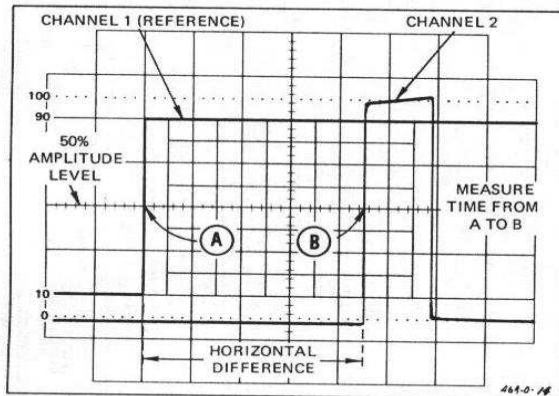

Fig. 9. Time differences between two pulses.

and the ALT position is more suitable for high-frequency signals. Center each of the displays vertically (see Fig. 9).

Measure the horizontal difference between the two signals. Multiply the measured difference by the setting of the TIME/DIV switch; if sweep magnification is used, divide this answer by 10.

EXAMPLE: The TIME/DIV switch is set to 50 μ s, the MAG switch to X10 and the horizontal difference between waveforms is 4.5 divisions (see Fig. 9).

Using the formula:

$$\text{Time Delay} = \frac{\text{TIME/DIV setting} \times \text{horizontal difference (divisions)}}{\text{magnification}}$$

Substituting the given values:

$$\text{Time Delay} = \frac{50 \mu\text{s} \times 4.5}{10} = 22.5 \text{ microseconds}$$

32

466/464 Operators

Ⓐ

MULTI-TRACE PHASE DIFFERENCE MEASUREMENTS

Use either the CHOP or ALT mode. Set A Trigger SOURCE switch to CH 1. The reference signal should precede the comparison signal in time. Use coaxial cables or probes that have equal time delay to connect the signals to the input connectors.

If the signals are of opposite polarity, set the INVERT pushbutton in to invert the Channel 2 display. (Signals may be of opposite polarity due to 180° phase difference; if so, take this into account in the final calculation.) Set the CH 1 and CH 2 VOLTS/DIV switches and the CH 1 and CH 2 VAR controls so the displays are equal in amplitude.

Set the TIME/DIV switch for about a one-cycle waveform and position the display and turn the A VAR TIME/DIV control for 1 reference signal cycle in exactly eight divisions (see Fig. 10). Each division of the graticule represents 45° of the cycle ($360^\circ \div 8 \text{ divisions} = 45^\circ/\text{division}$). The sweep rate can be stated in terms of degrees as 45°/division.

Measure the horizontal difference between corresponding points in the waveforms and multiply the distance measured (in divisions) by 45°/division (sweep rate) to obtain the amount of phase difference.

EXAMPLE: The horizontal difference is 0.6 division with a sweep rate of 45°/division is shown in Fig. 10.

Ⓐ

466/464 Operators

33

HIGH RESOLUTION PHASE MEASUREMENTS

Make more accurate dual-trace phase measurements by increasing the sweep rate (without changing the A VAR TIME/DIV control) by using the X10 MAG mode. Delayed sweep magnification may also be used (see Fig. 11).

EXAMPLE: If the sweep rate were increased 10 times with the magnifier, the magnified sweep rate would be $45^\circ \div 10 = 4.5^\circ/\text{division}$. Fig. 11 shows the same signals as used in Fig. 10 but with the X10 MAG switch set to X10. With a horizontal difference of 6 divisions, the phase difference is:

$$\text{Phase Difference} = \text{horizontal difference (divisions)} \times \text{magnified sweep rate (degrees/div)}$$

Substituting the given values:

$$\text{Phase Difference} = 6 \times 4.5^\circ = 27^\circ$$

34

466/464 Operators

Ⓐ

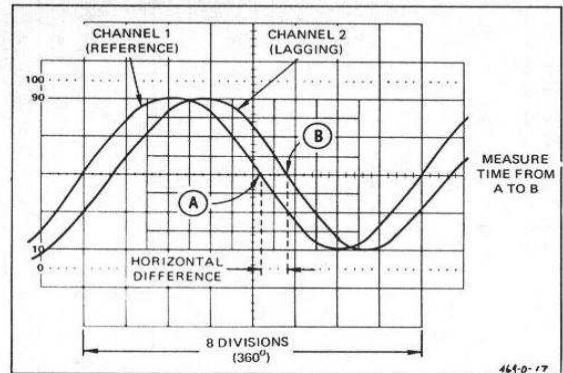

Fig. 10. Phase difference.

Using the formula:

$$\text{Phase Difference} = \frac{\text{horizontal difference (divisions)}}{\text{horizontal difference (divisions)}} \times \text{sweep (degrees/div)}$$

Substituting the given values:

$$\text{Phase Difference} = 0.6 \times 45^\circ = 27^\circ$$

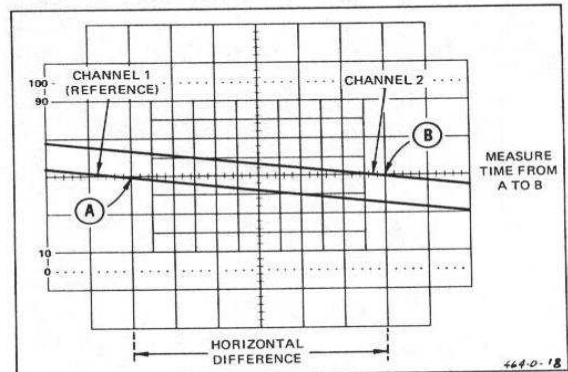

Fig. 11. High-resolution phase difference with increased sweep rate.

X-Y PHASE MEASUREMENTS

An alternate method for measuring the phase difference between two signals of the same frequency is the X-Y mode. This method is accurate for signal frequencies up to 50 kilohertz.

Set the TIME/DIV switch to X-Y and the X10 MAG switch to off. Position the display to graticule center of the screen and adjust the CH 1 and CH 2 VOLTS/DIV switches to produce a display less than 8 divisions vertically (Y) and less than 10 divisions horizontally (X). Center the display in relation to the center graticule lines.

Measure the distance A and B as shown in Fig. 12. Distance A is the horizontal measurement between the two points where the trace crosses the center horizontal line. Distance B is the maximum horizontal width of the display. Divide A by B to obtain the sine of the phase angle (Θ) between the two signals. The angle can then be obtained from a trigonometric table.

If the display appears as a diagonal straight line, the two signals are either in phase (tilted upper right to lower left) or 180° out of phase (tilted upper left to lower right) or if the display is a circle, the signals are 90° out of phase.

EXAMPLE: To measure the phase of the display shown in Fig. 12 where A is 5 divisions and B is 10 divisions, use the formula:

$$\text{Sine } \Theta = \frac{A}{B}$$

Substituting the given values:

$$\text{Sine } \Theta = \frac{5}{10} = 0.5$$

From the trigonometric tables: $\Theta = 30^\circ$

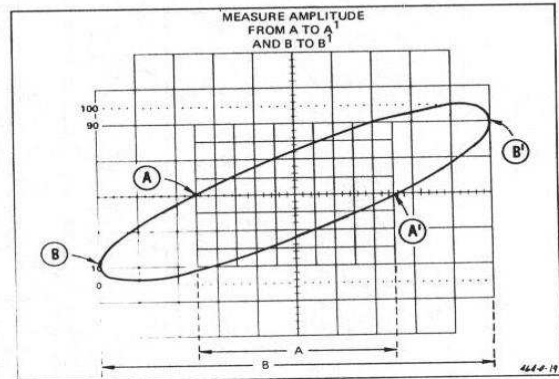

Fig. 12. Phase difference from an X-Y display.

Ⓐ

466/464 Operators

35

DELAYED OR MIXED SWEEP MEASUREMENTS

TIME. Use the delayed sweep mode to make accurate time difference measurements, between two pulses on the same trace, between two pulses from different sources (dual-trace), or duration of a single pulse.

Set the HORIZ DISPLAY switch to A INT and the B Trigger SOURCE to STARTS AFTER DELAY. Position the display as shown in Fig. 13A. Turn the DELAY-TIME POSITION dial to move the intensified portion to the first pulse.

Set the HORIZ DISPLAY switch to B DLY'D. Adjust the DELAY-TIME POSITION dial to move the pulse (or the rising portion) to some vertical reference line (see Fig. 13B). Note the setting of the DELAY-TIME POSITION dial.

Turn the DELAY-TIME POSITION dial clockwise to position the second pulse to this same point (if several pulses are displayed, return to the A INT position to locate the correct pulse). Again note the dial setting. Subtract the first dial setting from the second and multiply the difference by the delay time shown by the A TIME/DIV switch. This is the time difference between the pulses.

For the MIX mode of operation, the same general procedure can be used. With the first part of the display at

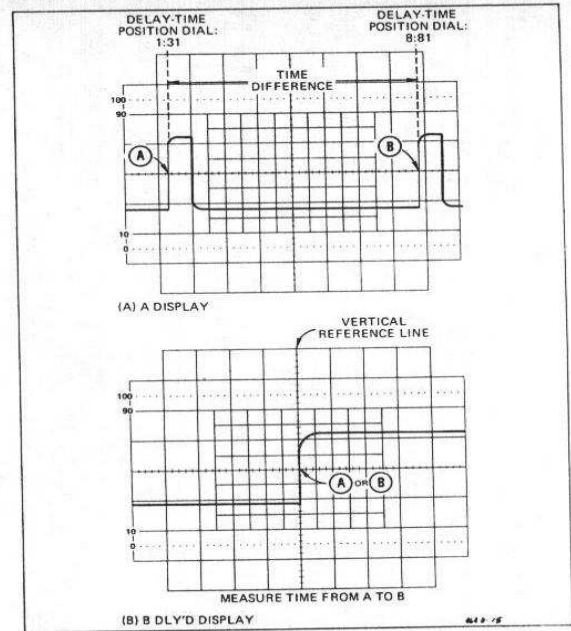

Fig. 13. Time difference using delaying sweep.

36

466/464 Operators

Ⓐ

a slower sweep rate set by the A TIME/DIV switch, it is necessary to switch display modes to insure location of the correct pulse. However, because of inaccuracies introduced into the measurement, a fixed graticule reference point cannot be used in the MIX mode in the manner normally recommended for making differential time measurements. The B DLY'D mode is considered the most accurate and therefore the recommended mode of making differential time measurements.

EXAMPLE: The first dial setting is 1.31 and the second dial setting is 8.81 with the A TIME/DIV switch set to $0.2 \mu\text{s}$ (see Fig. 13).

Using the formula:

$$\begin{array}{r} \text{Time} \\ \text{Difference} \\ \text{(delayed} \\ \text{sweep)} \end{array} = \begin{array}{r} \text{second} \\ \text{dial} \\ \text{setting} \end{array} - \begin{array}{r} \text{first} \\ \text{dial} \\ \text{setting} \end{array} \times \begin{array}{r} \text{delay time} \\ \text{(A TIME/DIV} \\ \text{setting)} \end{array}$$

Substituting the given values:

$$\begin{array}{l} \text{Time Difference} = \\ (8.81 - 1.31) \times 0.2 \mu\text{s} = 1.5 \text{ microseconds} \end{array}$$

MAGNIFICATION. Use the delayed sweep mode to gain high apparent magnification.

Set the HORIZ DISPLAY switch to A INT and B Trigger SOURCE switch to STARTS AFTER DELAY. Position the display as shown in Fig. 13A. Turn the DELAY TIME

POSITION to move the intensified portion to include the display to be magnified, changing the B TIME/DIV switch as needed.

Set the HORIZ DISPLAY switch to B DLY'D. Make the time measurement in the conventional manner.

For the MIX mode of operation set the HORIZ DISPLAY switch to MIX and make the time measurement in the conventional manner.

The apparent sweep magnification can be calculated by dividing the A TIME/DIV switch setting by the B TIME/DIV switch setting.

EXAMPLE: The apparent magnification of a display with an A TIME/DIV switch setting of $.1 \text{ ms}$ and a B TIME/DIV switch setting of $1 \mu\text{s}$ is:

$$\begin{array}{l} \text{Apparent Magnification} \\ \text{(Delayed Sweep)} \end{array} = \frac{\text{A TIME/DIV setting}}{\text{B TIME/DIV setting}}$$

Substituting the given values:

$$\begin{array}{l} \text{Apparent} \\ \text{Magnification} \end{array} = \frac{1 \times 10^{-4}}{1 \times 10^{-6}} = 100 \text{ times}$$

Objectionable jitter may be encountered using high magnification. Improved triggering may be obtained by setting the B Trigger SOURCE switch to the same position as the A Trigger SOURCE switch, increasing display amplitude (lower VOLTS/DIV setting) or triggering B Sweep externally.

Ⓐ

PULSE JITTER MEASUREMENTS

Be sure the VAR TIME/DIV switch is in the calibrated detent. Set the B TIME/DIV switch to intensify the full portion of the pulse. Set the HORIZ DISPLAY switch to B DLY'D.

Pulse jitter is shown by horizontal movement of the pulse and includes the inherent jitter of the Delayed Sweep (see Fig. 14). Multiply the distance by the B TIME/DIV switch setting to obtain pulse jitter time.

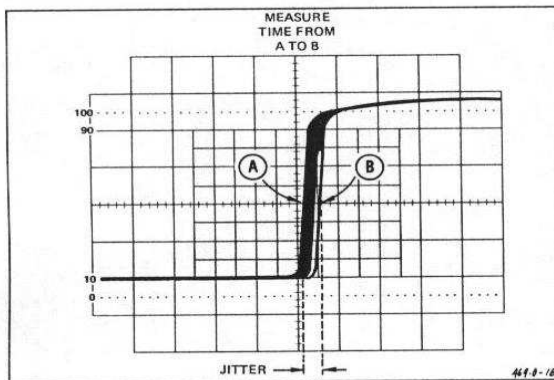

Fig. 14. Pulse jitter.

EXAMPLE: The horizontal movement is 0.5 division (see Fig. 14), and the B TIME/DIV switch setting is $0.5 \mu\text{s}$.

Using the formula:

$$\begin{array}{l} \text{Pulse Jitter} = \\ \text{(divisions)} \end{array} \times \begin{array}{l} \text{horizontal} \\ \text{jitter} \\ \text{setting} \end{array}$$

Substituting the given values:

$$\text{Pulse Jitter} = 0.5 \times 0.5 \mu\text{s} = 0.25 \text{ microseconds}$$

ALGEBRAIC ADDITION

The ADD position of the VERT MODE switch can be used to display the sum or difference (using CH 2 INVERT) of two signals, or for dc offset (applying a dc voltage to one channel to offset the dc component of a signal on the other channel). This does not require oscilloscope isolation or ungrounding.

The following general precautions should be observed when using the ADD mode.

1. Do not exceed the input voltage rating of the oscilloscope.
2. Do not apply signals that exceed an equivalent of about eight times the VOLTS/DIV switch setting. For

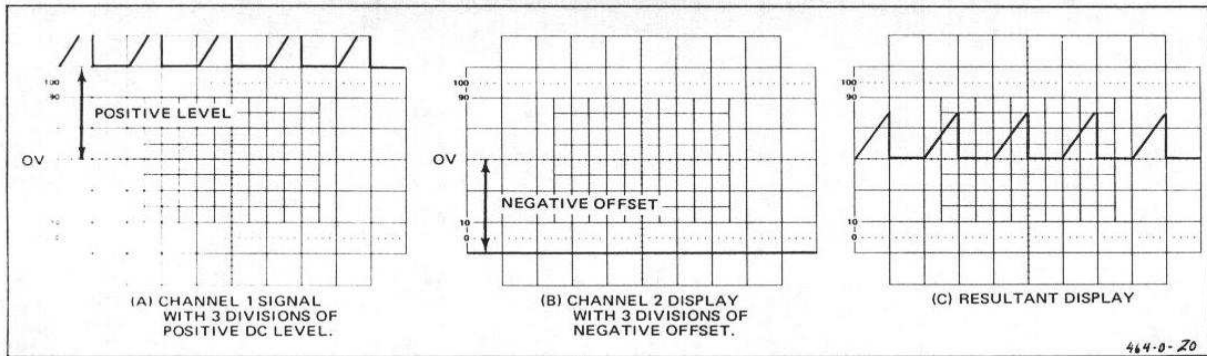

Fig. 15. Algebraic addition.

example, with a VOLTS/DIV switch setting of 0.5, the voltage applied to that channel should not exceed about four volts. Larger voltages may distort the display.

The total deflection factor in the ADD mode, when both VOLTS/DIV switches are set to the same position, is equal to the deflection factor indicated by either VOLTS/DIV switch.

EXAMPLE: The Channel 1 signal is on a 3 division, positive dc level (using the center line as zero volts). See

Fig. 15A. Multiply 3 divisions by the VOLTS/DIV switch setting to determine the dc-level value. Apply a negative dc level (or a positive level using the CH 2 INVERT switch), of the value determined, to Channel 2 input. See Fig. 15B. The ADD mode puts the resultant display within the operating range of the POSITION controls.

In some cases it may be possible to use an available voltage or signal for the offset by varying the CH 2 VOLTS/DIV, VAR VOLTS/DIV and INVERT controls – for example, the A + GATE signal.

Ⓐ

466/464 Operators

39

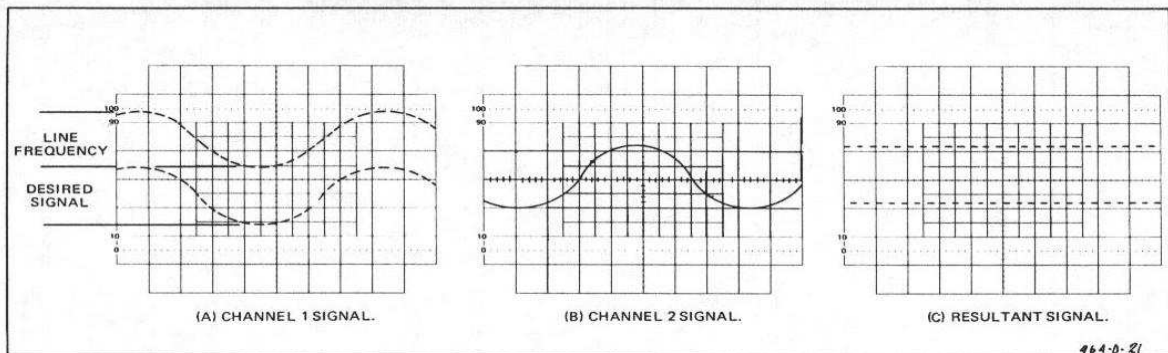

Fig. 16. Common mode rejection.

COMMON-MODE REJECTION

The ADD mode can be used to remove undesirable components from the display signal by using common-mode rejection. Observe the precautions given under Algebraic Addition.

The total deflection factor in the ADD mode when both VOLTS/DIV switches are set to the same position is equal to the deflection factor indicated by either VOLTS/DIV

switch. The amplitude of the display is the resultant crt deflection multiplied by the deflection factor indicated by either VOLTS/DIV switch.

EXAMPLE: The signal applied to Channel 1 contains unwanted line-frequency components (see Fig. 16A). A corresponding line-frequency signal is connected to Channel 2 and inverted using CH 2 INVERT switch. (See Fig. 16B.) Fig. 16C shows the desired portion of the signal as displayed when common-mode rejection is used.

40

466/464 Operators

Ⓐ

OPERATOR'S SPECIFICATIONS

Refer to the service manual for complete specifications. Specifications given are for an operating range of 0°C to +40°C unless otherwise stated.

STORAGE

STORED WRITING SPEED

VAR PERS Full Scan Speed: 0.5 div/ μ s over the center 6 X 8 divisions. It is necessary to use the STORAGE LEVEL control to compromise between writing speed and view time. 466 and 464.

FAST Full Scan Speed: 110 div/ μ s over the center 6 X 8 divisions (0.9 cm/div). 464 only.

FAST Full Scan Speed: 150 div/ μ s over the center 6 X 8 divisions (0.9 cm/div). 466 only.

FAST Reduced Scan Speed: 3,000 div/ μ s over the center 8 X 10 divisions (0.45 cm/div). 466 only.

VAR PERS Reduced Scan Speed: 3 div/ μ s over the center 8 X 10 divisions. It is necessary to use the STORAGE LEVEL control to compromise between writing speed and view time. 466 only.

Ⓐ

466/464 Operators

41

Common-Mode Rejection Ratio (ADD Mode with CH 2 Inverted): At least 10:1 at 20 MHz for common mode signals of 6 divisions or less with GAIN adjusted for best CMRR at 50 kHz.

Input Gate Current: 0.5 nA or less (0.1 div at 5 mV/DIV), from -15°C to +30°C.

Channel Isolation: At least 100:1 at 25 MHz.

CHOP Mode Repetition Rate: Approximately 250 kHz.

Cascaded Operation (CH 1 OUT into CH 2) sensitivity: at least 1 mV/DIV. Bandwidth is dc to at least 50 MHz, with CH 1 OUT connected to CH 2 Input, ac coupled, using a 50 Ω , 42-inch cable, terminated in 50 Ω at CH 2 Input.

TRIGGERING

SENSITIVITY

Ac Coupled Signal: 0.3 div internal or 50 mV external, from 30 Hz to 25 MHz; increasing to 1.5 div internal or 150 mV external at 100 MHz.

LF REJ Coupled Signal: 0.5 div internal or 100 mV external, from 50 kHz to 25 MHz; increasing to 1.5 div internal or 300 mV external at 100 MHz. Attenuates signals below about 50 kHz.

42

466/464 Operators

Ⓐ

STORAGE VIEW TIME

FAST and VAR PERS View Times: At least 15 seconds. These times are at full stored display intensity. They are extended at least 25 times by using reduced intensity in the SAVE Display mode.

VERTICAL

Deflection Factor Accuracy: within 3% in the calibrated position.

Frequency Response: Dc to at least 100 MHz for CH 1 and CH 2. Ac-coupled, low-frequency response is 10 Hz or less. Use of a 10X probe extends frequency response to 1 Hz.

Risetime: 3.5 nanoseconds or less.

Maximum Input Voltage: 250 V (dc + peak ac) or 500 V p-p ac at 1 kHz or less, dc coupled; 500 V (dc + peak ac) or 500 V p-p ac 1 kHz or less, ac coupled.

Positive-going Step Aberrations: Less than +3%, -3% and 3% peak-to-peak, excluding the ADD mode.

HF REJ Coupled Signal: 0.5 div internal or 50 mV external, from 30 Hz to 50 kHz. Attenuates signals below about 60 Hz and above about 50 kHz.

DC Coupled Signal: 0.3 div internal or 50 mV external, from dc to 25 MHz; increasing to 1.5 div internal or 150 mV external at 100 MHz.

EXT \div 10 Signal: amplitude requirements are multiplied by 10.

EXTERNAL TRIGGER INPUT

Maximum Input Voltage: 250 V (dc + peak ac) or 250 V p-p ac (1 kHz or less).

LEVEL CONTROL RANGE

EXT. is at least + and -2 V, 4 V p-p, EXT \div 10 is at least + and -20 V, 40 V p-p.

TRIGGER VIEW

Deflection Factor: About 50 mV/div in EXT and about 500 mV/div in EXT \div 10.

Risetime: 5 ns or less.

Trigger Centering Point: Within 1.0 division of screen center.

HORIZONTAL

Sweep Rate Accuracy: Within 2%, unmagnified, and 3% magnified, from +20°C to +30°C and in the calibrated position for A and B Sweeps.

Mixed Sweep Accuracy: Within 2% plus the measured A Sweep accuracy, when viewing the A portion only. B Sweep portion remains the same as above.

Trigger Holdoff Variable: Increases A Sweep holdoff time by at least a factor of 10.

Differential Time Measurement Accuracy: As shown:

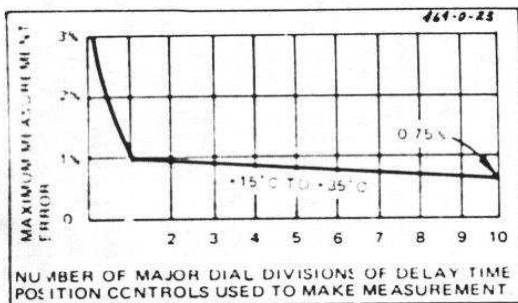

Delay Time Jitter: 1 part, or less, in 50,000 (0.002%) of 10 times the A TIME/DIV switch setting.

Calibrated Delay Time (VAR control to CAL): Continuous from 0.2 μ s to at least 5 seconds after the start of the A (delaying) sweep.

X-Y

X-Axis Sensitivity (X10 MAG turned off): Same as the vertical system.

X-Axis Bandwidth: Dc to at least 4 MHz, with a 10 division reference signal.

Phase Difference Between X- and Y-Axis Amplifiers: Within 3% from dc to 50 kHz.

Deflection Accuracy: Within 4%.

CALIBRATOR

Output Voltage: 0.3 V within 1% and within 0.3% from +20°C to +30°C.

Output Current: 30 mA within 2% from +20°C to +30°C.

Repetition Rate: About 1 kHz.

Ⓐ

466/464 Operators

43

Z AXIS INPUT

Sensitivity: Noticeable modulation at normal intensity by a 5 V p-p signal. A positive-going signal decreases intensity.

Frequency Range (Usable): Dc to 50 MHz.

Maximum Input Voltage: 100 V (dc plus peak ac) or 100 V p-p ac at 1 kHz or less.

OUTPUTS

CH 1 OUT

Output Voltage: At least 50 mV/div into 1 M Ω to at least 25 mV/div into 50 ohms.

Bandwidth: Dc to at least 50 MHz into 50 ohms.

Dc Level: About 0 volts.

A AND B GATES

Output Voltage: About 5.5 V of positive-going pulse.

Output Resistance: About 500 ohms.

44

466/464 Operators

Ⓐ

AC POWER SOURCE

Line RMS Voltage Ranges:

	115V		230V
Low	99 V to 121 V	Low	198 V to 242 V
Medium	104 V to 126 V	Medium	207 V to 253 V
High	108 V to 132 V	High	216 V to 264 V

Line Frequency: From 48 Hz to 440 Hz.

Maximum Power Consumption: 100 watts at 115 V, 60 Hz, medium range.

ENVIRONMENTAL

Operating Temperature: -15°C to +55°C.

Operating Altitude: To 15,000 feet. Maximum operating temperature decreases 1°C/1000 feet, above 5,000 feet. Storage temperature is to 50,000 feet.

Humidity (Operating and Storage): 5 cycles (120 hours) referenced to MIL-E-16400F.

ACCESSORIES

STANDARD ACCESSORIES INCLUDED

2 Probe Packages, P6062A	010-6062-03
1 Accessory Pouch, Snap	016-0535-02
1 Accessory Pouch, Zipper	016-0537-00
1 Service Manual (464)	070-1653-00
1 Service Manual (466)	070-1753-00
1 Operator's Manual (466/464)	070-1652-00
2 Fuses, 1.5A 3AG fast-blow	159-0016-00
2 Fuses, 0.75A 3AG fast-blow	159-0042-00
1 Filter, Blue Plastic (installed)	337-1674-00
1 CRT Filter, Clear Plastic	337-1674-01
1 Adapter, Ground Binding Post	134-0016-01
1 Visor, CRT: Folding	016-0592-00

1105 Battery Power Supply — Provides 1.6 hours (464 and 466); 1.8 hours (465); 1.4 hours (475) of battery operation. Order 1105 Battery Power Supply.

Protective Cover — Waterproof, blue vinyl. Order 016-0554-00

Folding Polarized Viewing Hood — Order 016-0180-00

Folding Viewing Hood, light-occluding — Order 016-0566-00

Mesh Filter — Improves contrast and EMI filtering. Order 378-0726-01

SCOPE-MOBILE Cart — Occupies less than 18 inches aisle space, has storage area in base, order 200.

OPTIONAL ACCESSORIES

P6105 10X Probe Package, order 010-6105-03

C30A-P Option 1 Compact Camera — f/1.9 lens, 0.8 magnification, Polaroid Land Pack Film back for 3000-speed film (includes Adapter Frame/Corrector Lens 016-0301-00), order C30A-P Option 1

Camera Adapter and Corrector Lens — Adapts C30-A to 464, 465, 466, or 475. Order 016-0301-00.

1106 Battery Pack — This unit permits freedom to operate the Tektronix 464, 465, 466, or 475 Option 7 oscilloscope at remote locations or when isolation from the line or ground is required. It supplies 24 volts dc at a 140 watt-hour capacity. The 1106 connects to the oscilloscope, or the oscilloscope and battery pack can be carried or operated separately. For carrying ease, this provides two packages of almost equal weight, each with its own handle. Because the 1106 can easily be disconnected from the oscilloscope and has an internal battery charger, the oscilloscope can be operated on external ac or dc or from a second 1106 while the batteries are being recharged.

REV. D, JUNE, 1976

466/464 Operators

45

1106 SPECIFICATIONS

CHARACTERISTIC	PERFORMANCE REQUIREMENT
POWER OUTPUT	
Output	22 to 24 volts dc
Battery Operating Time	140 watt hours from fully charged external batteries.
POWER SOURCE (Charging)	
AC Requirements	90 to 132 Vac, 50 to 400 Hz or 180 to 264 Vac, 50 to 400 Hz.
Power Consumption	60 watts maximum.
Battery Charging Time	14 to 16 hours.

ENVIRONMENTAL CAPABILITIES

Temperature	
Operating	0°C to +40°C
Non-operating with batteries	-40°C to +60°C
without batteries	-55°C to +75°C

DIMENSIONS AND WEIGHTS

Height	2.3 in	5.8 cm
Width	12.9 in	32.7 cm
Depth	17.0 in	43.2 cm
Net Weight	16.4 lb	7.4 kg
Domestic Shipping Weight	≈ 19.4 lb	≈ 8.8 kg
Export-packed Weight	≈ 26.4 lb	≈ 12.0 kg

Included Accessory: Power Cord (IEC female, NEC male) 161-0066-00

Order 1106 BATTERY PACK

OPTIONS

Your instrument may contain the following options:

OPTION 4

The instrument is modified to meet certain specifications on radiated interference requirements. There is no change in operating instructions.

OPTION 7

The instrument is modified to permit operation on 12 or 24 Vdc with no performance deterioration. Circuitry is provided to protect against damage due to connection of 24 V when in the 12 V mode of operation. The 24-volt external input permits use with conventional dc power (marine and aircraft).

Option 7 is an integral part of the oscilloscope. The modified oscilloscope has a three-position voltage input selection slide switch (visible through the right-hand side panel) at the rear of the line voltage selector switch. A dc input connector is located below the fan cover on the rear panel.

CONTROLS AND CONNECTORS

Mode Switch

AC

Applies ac power to the oscilloscope power switch.

DC 12

Permits 12 V operation of the instrument from an external 12 V source.

DC 24

Permits 24 V operation of the instrument from either an external 24 V power source or from the 1106 Power Supply, which may be mechanically attached to the oscilloscope.

DC Input Connector

Option 7 mode switch and DC Input connector are located on the modified oscilloscope.

Ⓐ

466/464 Operators

47

OPERATION

Set the oscilloscope and Option 7 for the power source available as listed below:

Power Source	Oscilloscope Line Selector	Option 7 Mode Switch
115 Vac	115	ac
230 Vac	230	ac
12 Vdc	—	12
24 Vdc	—	24
1106 ¹	—	24

¹The 1106 Battery Pack is a dc power source that attaches to the oscilloscope feet. It provides typically 1.7 hours of battery operation with good, properly charged batteries. Since it contains a battery charger, be sure that the 1106 Line Selector switch is set to the correct line voltage for proper battery charging.

Turn the oscilloscope on. The oscilloscope operates properly on any of the listed power sources that may be available.

Connect the oscilloscope frame to a ground (earth) reference before using.

48

466/464 Operators

Ⓐ

SPECIFICATIONS

AC REQUIREMENTS. No increase in ac requirements over those of oscilloscopes not having Option 7.

DC REQUIREMENTS. 11.5 to 14 volts or 22 to 28 volts. 11.5-volt operation excludes graticule light operation.

Maximum operating current for the 464 and 466 is 8.5 amperes on the 12 volt range and 4 amperes on the 24 volt range. Operating range may be extended to 15 volts or 30 volts with a series dropping resistor. Maximum elevation for + or - power lead is 60 volts with respect to oscilloscope chassis ground.